

Important Router Information

Dear Valued Customer:

This packet includes **important information about your equipment** which should be reviewed by you prior to speaking with our Installations Group.

It is not a replacement for our Technical Support but is designed to help us help you get your internet connection up and running as quickly as possible.

Our Installations Group will work with you via one hour appointments. **Please review this packet and follow the setup flowchart prior to your initial appointment with your Installations Representative**

Thank you very much and welcome to the Internet.

Technical Support: (888) 774-4206

Enclosed are the following documents regarding your Internet equipment:

- **Router Setup Flowchart**
- **Connectivity Flowchart**
- **Configuration Print Out**
- **Configuration Instructions**

Additional documents for Leased Line Customers:

- **Astrocom CSU/DSU Diagram**
- **Important Circuit Information**

Setup: Livingston IRX 211 – Leased Line

Instructions for connecting your Livingston IRX 211 Router for your leased line account:

Prerequisites: Please run through the following flowchart to connect your equipment prior to scheduling your initial appointment with our Installations Group.

- Local Area Network (LAN) already setup
- TCP/IP configured on the individual workstations
- Circuit installed and tested - you will receive a message from us asking you to call for your installation appointment. Equipment should not be connected until this message is received.

Your router has been shipped to you preconfigured. Please check the configuration print out to verify that your Serial IP address and the DLCI number for your connection has been included. Also, when the connection is up and running, don't forget to change the router password.

Start Setup Flow

Connect the cable from the S1 port on the back of the router to the CSU/DSU and the RJ45 cable from the CSU/DSU line port to the demarc.

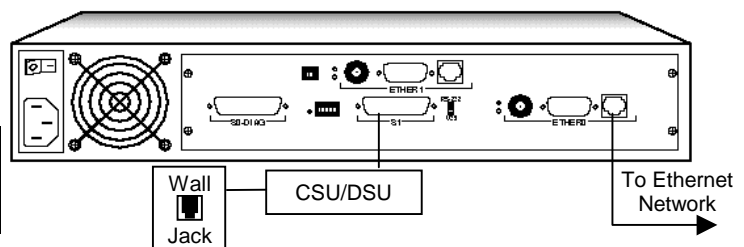

Is your LAN connected to a hub?

No

Connect a cross over RJ45 cable from the ETHER0 port directly to your Ethernet card.

Yes

Connect the straight through Ethernet (RJ45) cable from the ETHER0 port on the back of the router to your 10BaseT Hub.

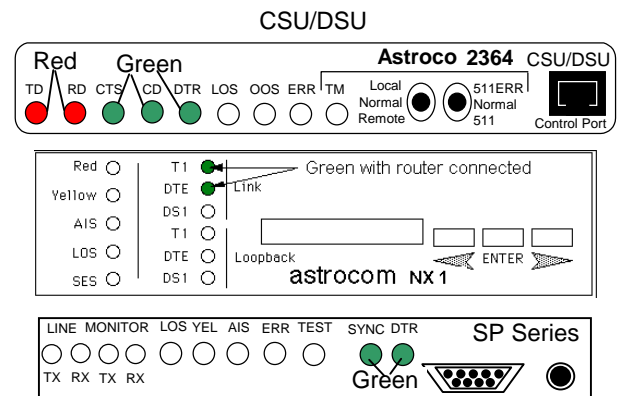

Turn on the CSU/DSU then the router. Wait about 90 seconds. The router should have a good connection. Check the lights on your CSU/DSU (see diagrams).

Do the lights match the diagram of your model CSU/DSU?

No

Power down the router and the CSU/DSU. Try each of the following and then power up the CSU/DSU, then the router:

- Verify the cables are connected (see Astrocom diagram document).
- Swap cable with a different straight through RJ45 cable to the wall jack.
- Astrocom 2364 (56k service only)-both switches should be set to Normal and nothing connected to the Control Port.

LOS (Loss of Signal) – no signal from telco
 DTR or DTE – no signal from router (power up router after CSU/DSU)
 -check cable and/or configuration

If the lights still do not match the diagrams above, troubleshooting will need to be completed by our

Technical Support Group with you and/or the Telephone Company.

Check Connectivity. See Connectivity Flow Chart.

Connectivity:

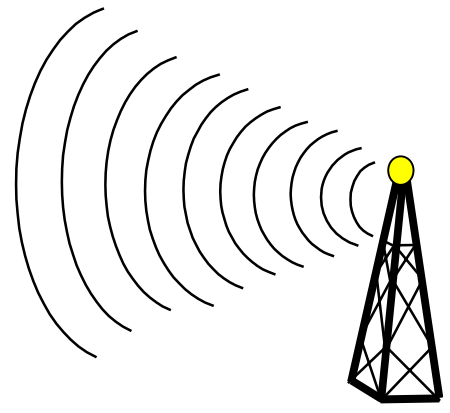
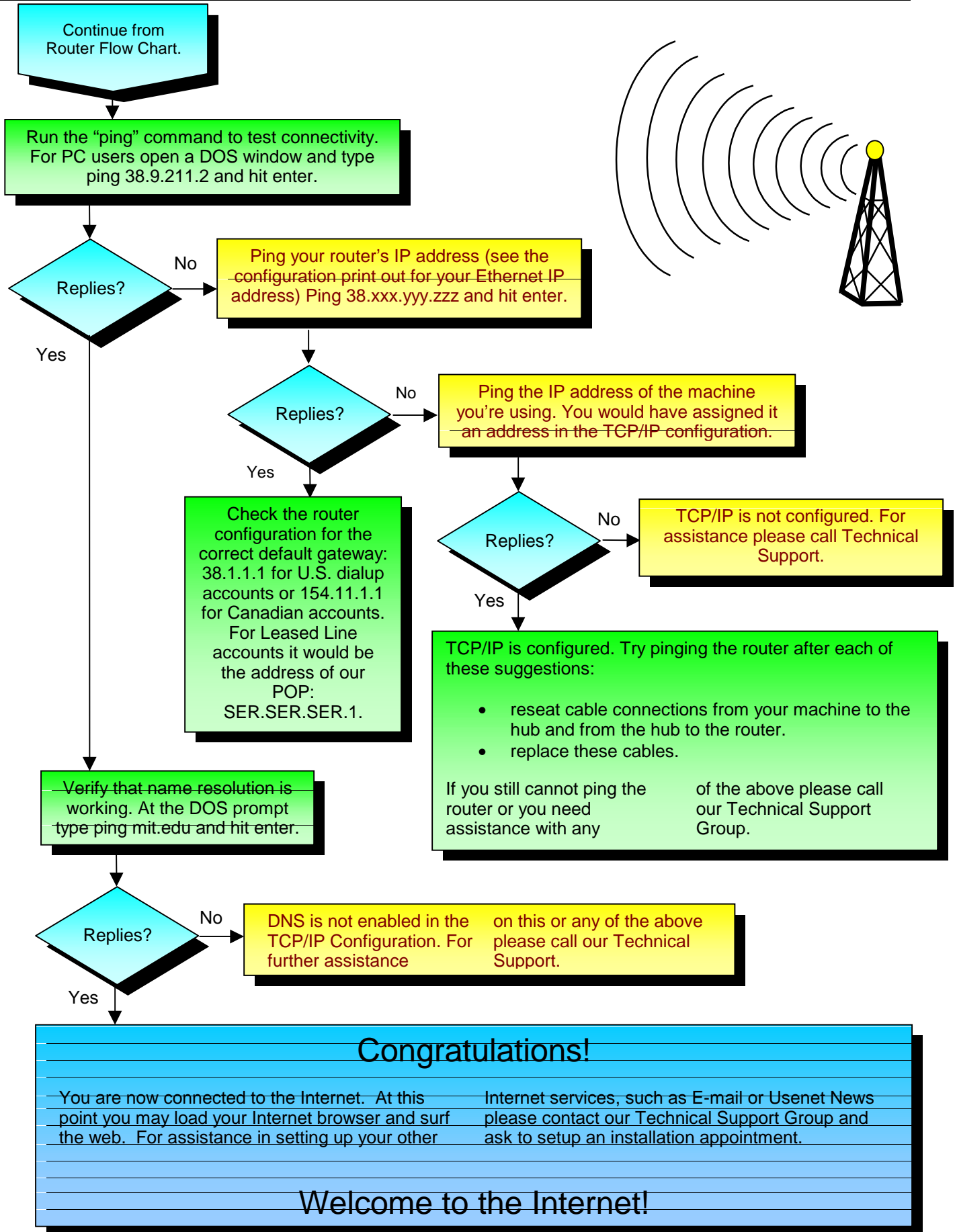

Configuring the Livingston IRX-211 – Leased Line

If you received your router from us it should be preconfigured. You can telnet into the router if adjustments need to be made to the configuration.

If not preconfigured you must connect a console to the Console port of the router. A null modem cable is required. Connect the null modem to the S0 console port of the IRX-211 and to a PC (or Mac with proper cables) with VT100 emulation software set to 9600, 8, none 1. If the router has not been preconfigured, it will run through an interactive script upon bootup.

Ports: 2 Ethernet ports: AUI/Built-in thinnet (BNC) / Built-in 10BaseT (RJ45)
 1 synchronous serial port RS-232 and V.35 interfaces
 1 synchronous serial port DB-25 connector

Enter the configuration at the command line with **bold** entries according to the key.

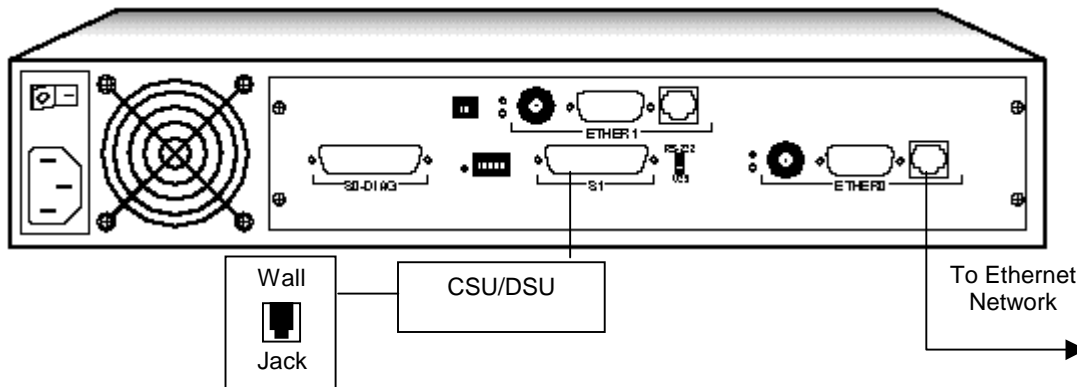

Router Configuration:

```
set address LAN.LAN.LAN.LAN
set netmask 255.255.255.0
set gateway SER.SER.SER.1 1
set snmp readcommunity public
set routing on
set ethernet up
set broadcast high
set snmp on
set telnet 23
set s1 mtu 1500
set s1 cd on
set s1 protocol fr
set s1 lmi 4
set s1 speed LINE.SPEED
set s1 address SER.SER.SER.SER
set s1 destination 255.255.255.255 255.255.255.0
set s1 DLCI DLCI:SER.SER.SER.1
set s1 extended on
set s1 routing broadcast
set default broadcast
save all
save snmp
save route
save pass
```

Key:

LAN.LAN.LAN.LAN	= Customer router IP address
LAN.LAN.LAN.0	= Customer class C network
LAN.LAN.LAN.255	= Customer broadcast address
SER.SER.SER.SER	= Customer router serial IP address
SER.SER.SER.1	= Local POP IP address
SER.SER.SER.255	= Customer serial IP broadcast address
DLCI	= Customer DLCI number
LINE.SPEED	= Customer line speed (56000 or T1)

Astrocom Troubleshooting

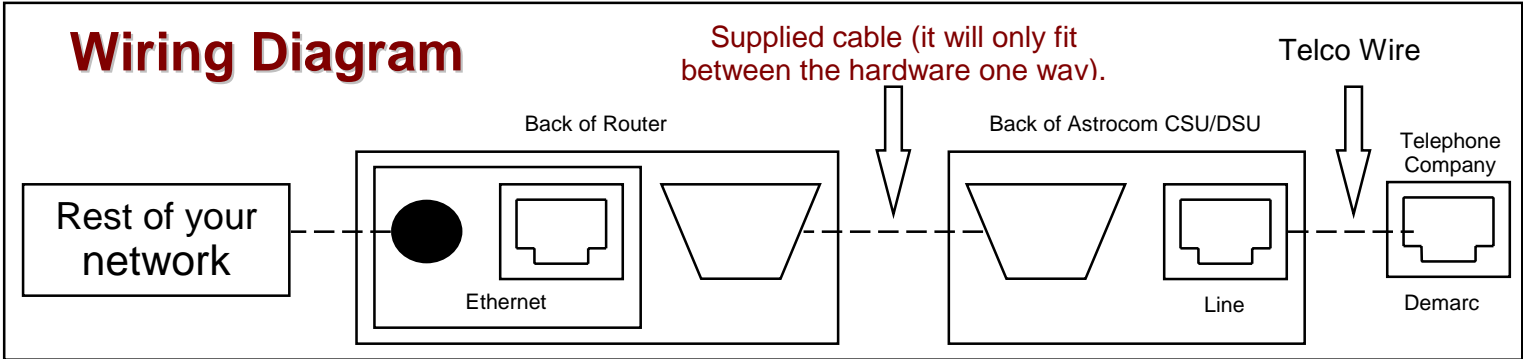
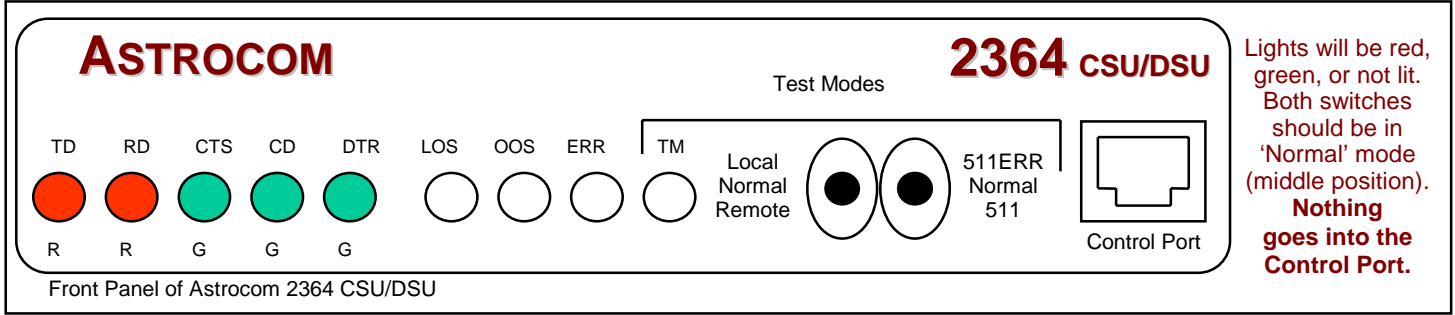

Troubleshooting your connection and hardware: What you should see:

1) Confirm the settings on the bottom of the Astrocom. See diagram below.

	TD	RD	CTS	CD	DTR	LOS	OOS	ERR	TM
2) Plug in the power cord only and turn it on.	R	R	G	R	---	R	---	---	---
3) Put it into local loopback mode (put the left dip switch up).	R	R	G	G	---	---	---	---	R
4) Do hard loop (both switches to normal, put loop plug in line port).	R	R	G	G	---	---	---	---	---
5) Leave settings as above, and put 511ERR switch to up.	R	R	R	G	---	---	---	flash	R
6) Move switches to normal, and now plug in actual Telco circuit.	R	R	G	G	---	---	---	---	---
7) Plug router in to the CSU and turn it on.	R	R	G	G	G	---	---	---	---

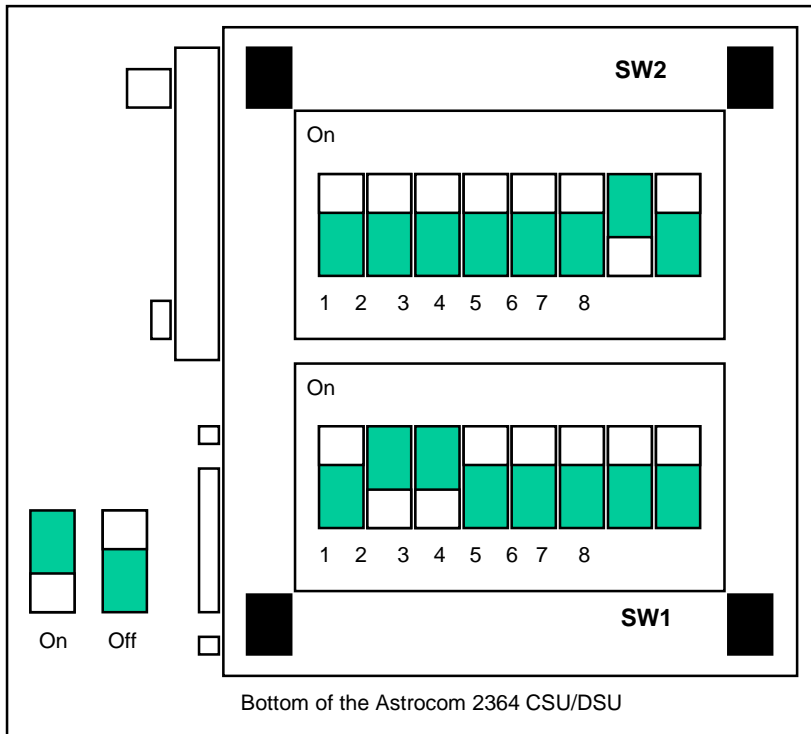

Important Circuit Information

This document is designed to give you a general idea of what is involved in building a circuit for your Internet use.

You will be receiving weekly status updates which include the following dates concerning your Leased Line Circuit:

- Date the circuit was ordered by us.
- Estimated date of circuit installation (unconfirmed)
- Scheduled date of circuit installation (if provided by the telco)
- Date circuit turn up was accepted by our Network Operations Group

Once the circuit has been accepted by NOPs you will receive an “available” message indicating that the circuit is ready and to call our Corporate Installations Group to setup your initial appointment.

Please be aware that the circuit is not ready until you receive this message. It is often thought that when the circuit is installed at your site that all is ready to go. Sometimes it is, sometimes it is not. The following is a simple diagram of a circuit:

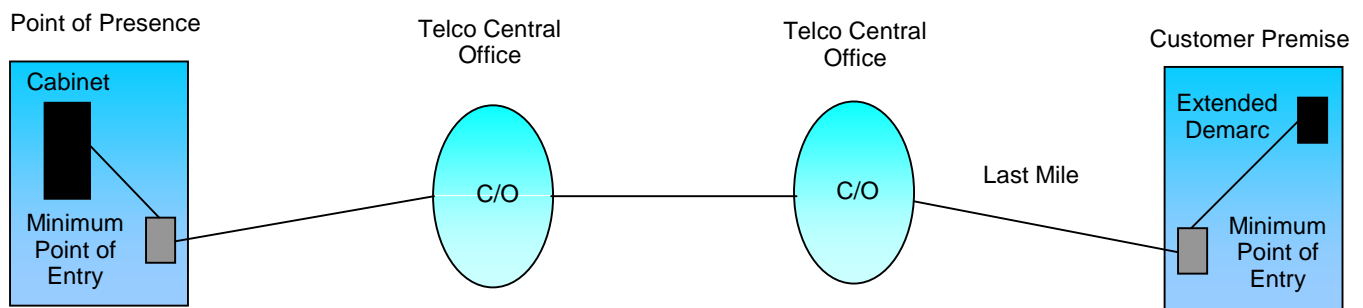

General Process:

1. The circuit is ordered by us with the telco. The telco “designs” the circuit from our Point of Presence (POP) to your site’s Minimum Point of Entry (MPOE).
2. The telco completes the circuit from our POP, through the Central Office(s), to your MPOE. An extended demarc needs to be run from the MPOE to your equipment room which is usually handled by the telco.
3. When the telco is done they will contact us to test the line. When test is complete and satisfactory you will be sent a message asking you to setup your initial appointment.

Some Pitfalls:

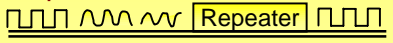
1. Due to timing, design changes may be required at one or more Telco Central Office.
2. Facilities problems occur, usually in the “Last Mile.” For example, construction requirements, repeaters required to “clean up” the signal. 
3. All looks ready to go but you still cannot get a good connection. It may be that a loop has been left at one of the Telco Central Offices not allowing the signal to reach your site. We have no way of knowing this at the time of testing but our Operations Group will work with the Telco to resolve.